

### Power Connections

Use the 2 way terminal connector provided to connect the unit to the ships supply. Ensure the connector is wired as indicated in Fig. 3.

Fig. 3: Power supply

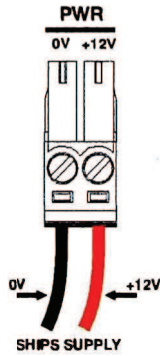

Note: If the alarm is active on Box 2 the Green LED indicator on Box 1 will show an extended flash whenever a radar pulse is detected. For correct indication, it is suggested to use the alarm on Box 1 only.

When using an external alarm, the alarm should be wired to Box 1, as shown in Figure 7.

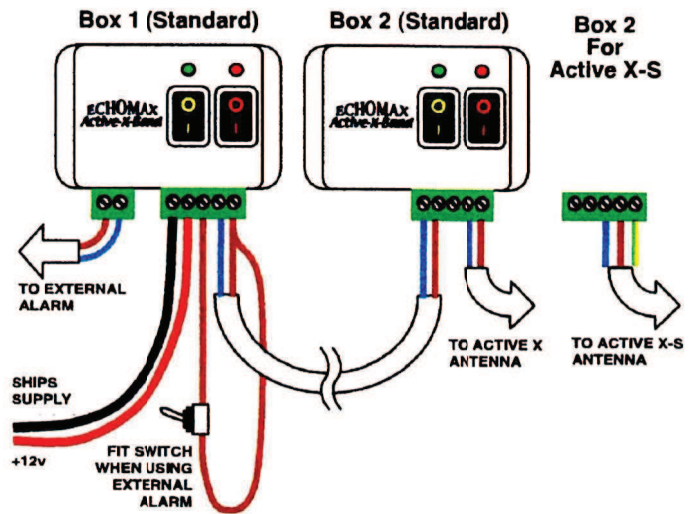
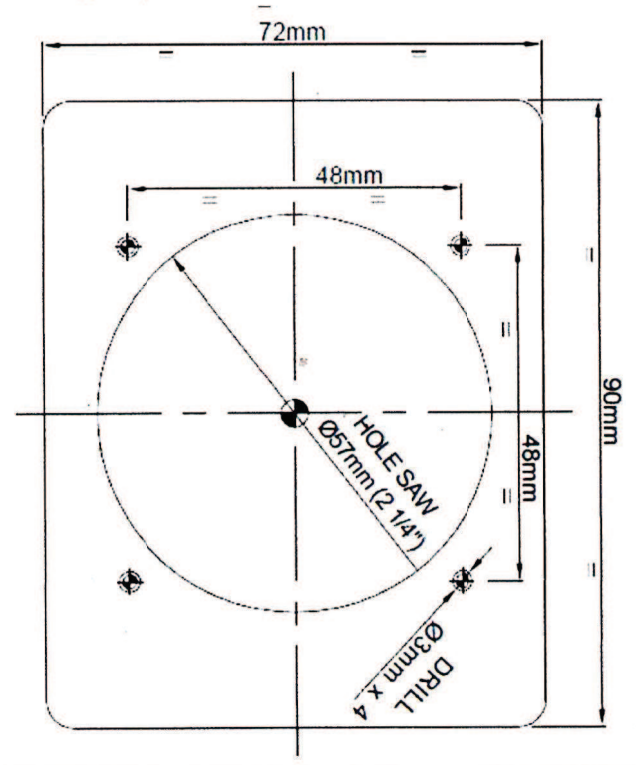

Fig. 7: Connection of External Alarm

For further information on wiring external alarms, see the Active-X and ActiveX-S Operation Manuals

### Cutting Template



Manufactured by

Echomax Products in the UK

PO Box 6032, Dunmow CM6 3AS, UK.

Email: [echomaxsales@aol.com](mailto:echomaxsales@aol.com) [www.echomax.co.uk](http://www.echomax.co.uk)

Tel: 00 44 (0) 1371 830216 Fax: 831733

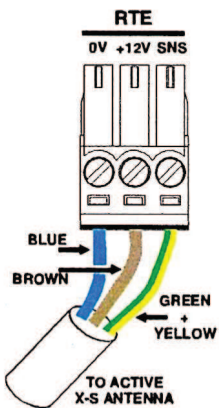

### RTE Connections

Use the 3 way terminal connector provided to connect the unit to the active X-S antenna. Ensure the connector is wired as indicated in Fig. 4. If an X Band RTE is being wired just connect the blue and brown wires.

Fig. 4: RTE connectivity

### External Alarm Connections

The unit has the ability to supply a switched signal for an external alarm. This alarm will operate along with the internal audible alarm. Use the 4 way terminal connector, provided, to connect the unit to the external alarm. Ensure the connector is wired as indicated in Fig. 5. The "EXT ALARM" connections are a switched relay. The user must provide an external signal to be switched through these relay connections.

To enable the external alarm the "EXT ALARM ENABLE" connections must be linked together. It is suggested that this link is made through a toggle switch to provide a means of disabling the external alarm.

Note: disabling the internal audible alarm WILL NOT affect the external alarm.

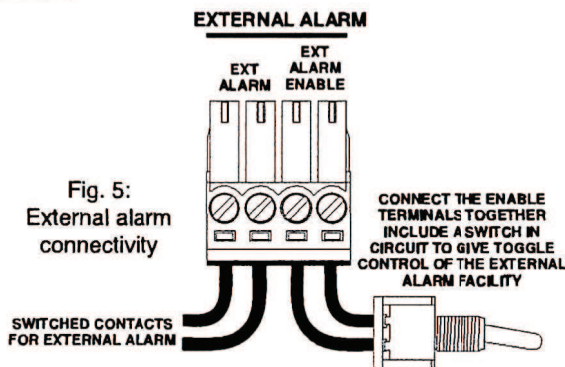

Fig. 5: External alarm connectivity

### Using Dual Control Boxes with Active-X & X-S RTE

The standard control box may be dual stationed to an exterior waterproof one as shown below.

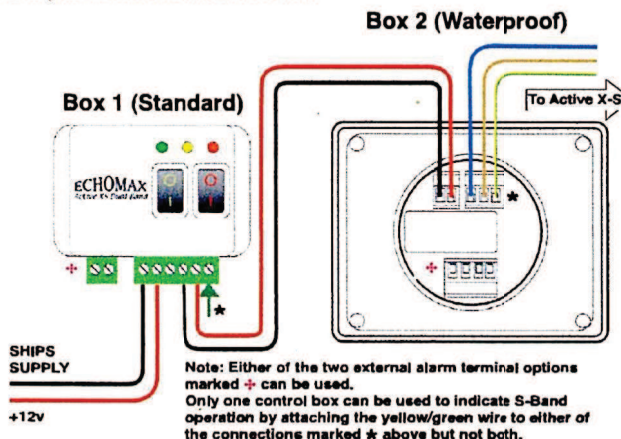

Fig. 6: Dual station connection